

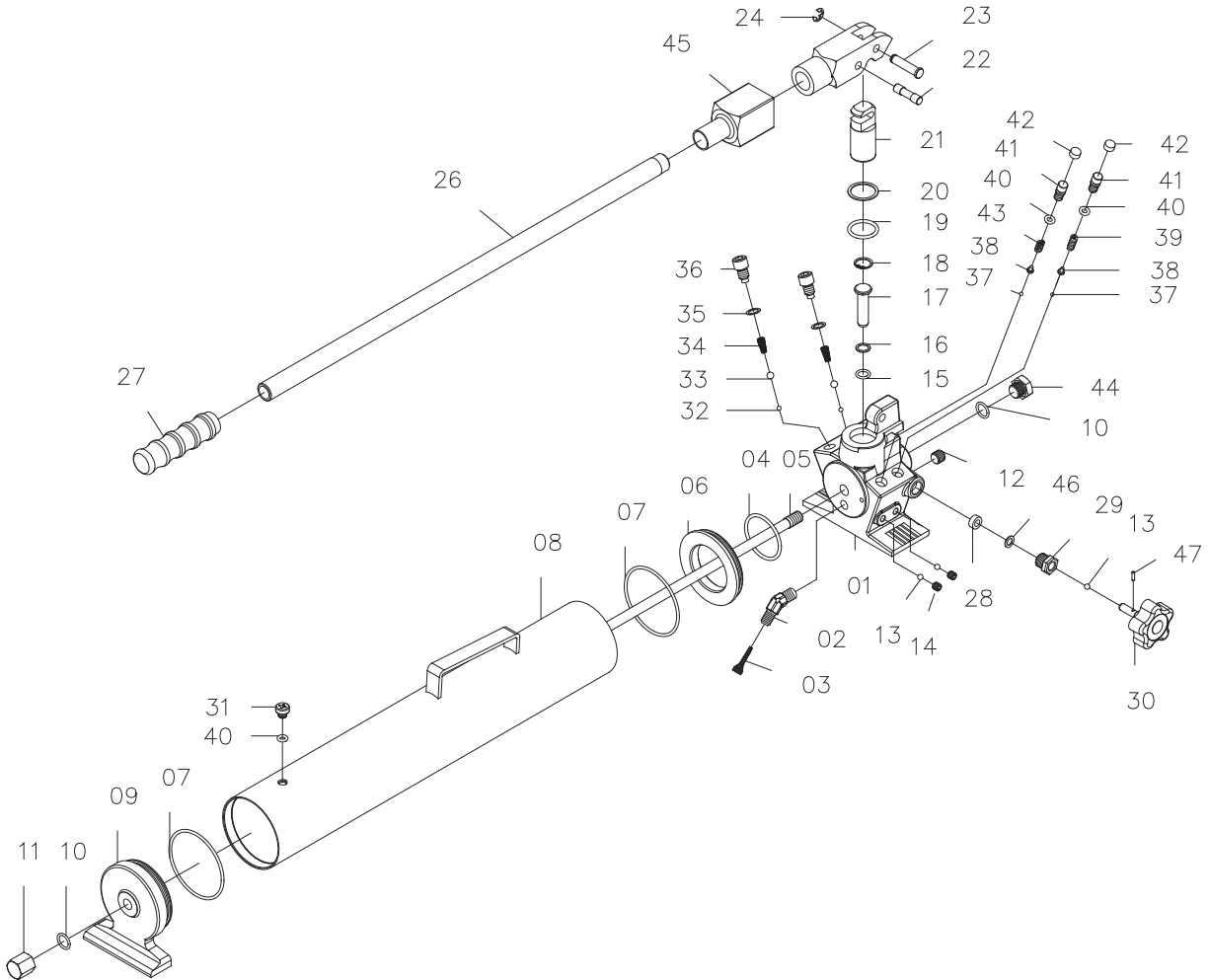

ZHP-150 Parts Breakdown

Toll Free: 1-800-579-8088 Web: www.zinko.com

REV 101607



#	Description
1	Pump Housing
2	Elbow
3	Oil Filter
4	O-Ring
5	Screw
6	Head Base
7	O-Ring
8	Reservoir
9	Tail Base
10	O-Ring
11	Nipple
12	Screw

#	Description
13	Check Ball
14	Set Screw
15	O-Ring
16	Backup Ring
17	Pump Piston
18	Snap Ring
19	O-Ring
20	Backup Ring
21	Pump Piston
22	Piston Pin
23	Yoke Pin
24	Retaining Pin

#	Description
25	Yoke
26	Handle
27	Handle Grip
28	Oil Seal
29	Couplers
30	Release Valve
31	Air Release Screw
32	Check Ball
33	Check Ball
34	Spring
35	Washer
36	Valve Cover Screw

#	Description
37	Check Ball
38	Spring End Cap
39	Long Sep. Screw
40	O-Ring
41	Ovld. Cover Spring
42	Cap
43	Short Sep. Spring
44	Screw
45	Yoke Cover
46	Washer
47	Pin